

MR-4 SETUP

DATUM: 20.1.2002

ORT: Jetelingen

FAHRER Peter Schulz-Nowak

VORNE

LÄNGE	60mm
EINSTELLCLIPS	keiner
KOLBENSCHIEBE	3
INNERE DISTANZSCHEIBE	keine
FEDER	Yokomo gelb
ÖL	500

PLASTIKAUGE	
LANG	X KURZ

DÄMPFER	
PLASTIK	X ALU

VORDERER STABI	
X JA	silber

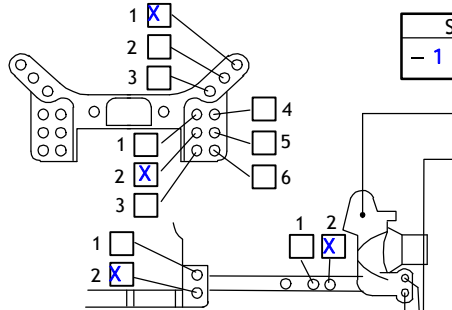

STURZ VORNE	
- 1	+

NACHLAUF	
STANDARD 5 GRAD	X
TEAM SUZUKI 3 GRAD	
TEAM SUZUKI 5 GRAD	
TEAM SUZUKI 7 GRAD	

REIFEN	
Graupner XR28	

EINLAGE	
Yokomo ZR-037F	

VORSPUR	
- 0	+
VORNE	

BODENFREIHEIT	
5 mm	

Teilebeschreibung	STANDARD	GRAPHIT
BULKHEAD		
DÄMPFERBRÜCKE		
SCHWINGEN		
LENKHEBELTRÄGER		
LENKHEBEL		

HINTEN

LÄNGE	60mm
EINSTELLCLIPS	keine
KOLBENSCHIEBE	3
INNERE DISTANZSCHEIBE	keine
FEDER	K3 gold
ÖL	500

PLASTIKAUGE	
LANG	X KURZ

DÄMPFER	
PLASTIK	X ALU

HINTERER STABI	
X JA	silber

VORSPURBLOCK		
0	1	2

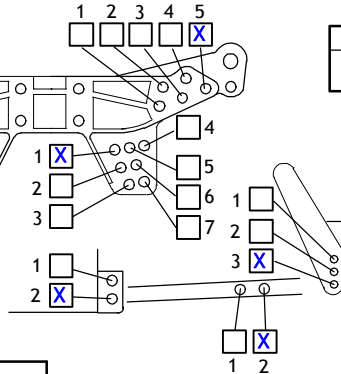

STURZ HINTEN	
- 1	+

Teilebeschreibung	STANDARD	GRAPHITE
BULKHEAD		
DÄMPFERBRÜCKE		
SCHWINGEN		

REIFEN	
Graupner XR28	

EINLAGE	
Yokomo ZR-037F	

BODENFREIHEIT	
5,3 mm	

CHASSIS	
X	SP SCHMAL (TC SPECIAL)
	GRAPHIT BREIT CHASSIS
	STANDARD BREIT CHASSIS

KAROSSERIE		
Dodge Stratus		
SPOILER		
VORDERES DIFF		
DIFF	X FREILAUF	
MITTELANTRIEB		
X	DIREKT	FREILAUF
FAHRTENREGLER		
NOVAK Cyclone TC2		

OBERE VERSTÄRKUNGSBRÜCKE	
STANDARD	X GRAPHIT
X	EINTEILIG
MOTOR	
TURN	FACH
17x2 DMC Standard	
UNTERSETZUNG	
RITZEL	HAUPTZAHNRAD
23 T	81 T
AKKU	
KEIL-Bilek Sanyo V+ 3000HV	
REIFENREINIGUNGSMITTEL	

BEMERKUNGEN:

Sehr kleine Halle bzw. Strecke. 1 Platz.

Weitere Set-ups: www.christian-keil.com/setup01.html

